

# CAB OPTIONS

Columbia Elevator offers the elevator contactor and design professional an extraordinary selection of cabs to address any situation: Commercial, LULA (Limited Use / Limited Application), and Residential

Columbia's commercial passenger cab line offers an unlimited variety of aesthetic features for use in office complexes, apartment building, hospitals, etc. Whether the cab is manufactured using a steel shell, wood core or steel shell with hanging panels, the building owner can rest assured that the product will bear a UL label certifying code compliance. Contractors engaged in new construction may use any of Columbia's cab designs: those engaged in modernization are benefited by the use of our patented Instafast™ technology

CE OFFERS AN UNLIMITED SELECTION OF FINISHES

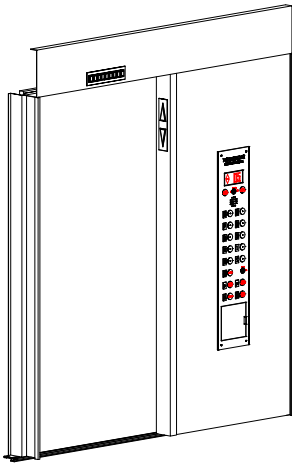

**SINGLE-SPEED  
SIDE OPENING**



**Nickle Bronze  
(Nickle Silver)  
(Single-Speed Shown)**

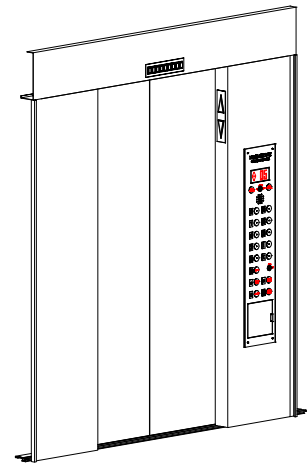

**SINGLE-SPEED  
CENTER OPENING**

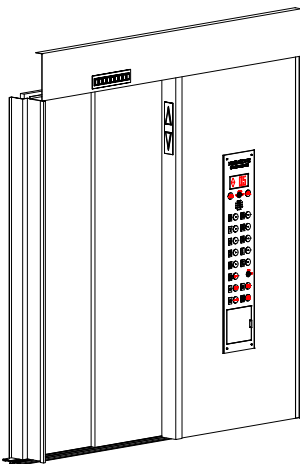

**TWO-SPEED  
SIDE OPENING**



**Yellow Bronze  
(Two-Speed Shown)**

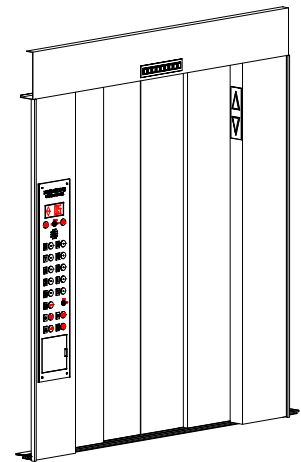

**TWO-SPEED  
CENTER OPENING**

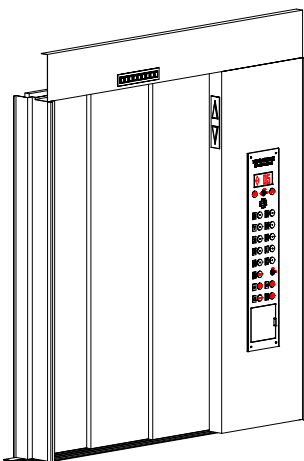

**THREE-SPEED  
SIDE OPENING**



**Aluminum or Stainless  
(Three-Speed Shown)**

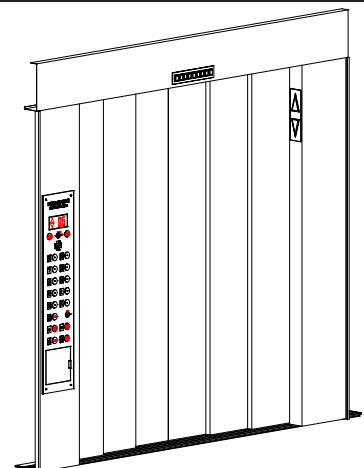

**THREE-SPEED  
CENTER OPENING**

FULL SELECTION FOR AESTHETICS AND EASE OF MAINTENANCE

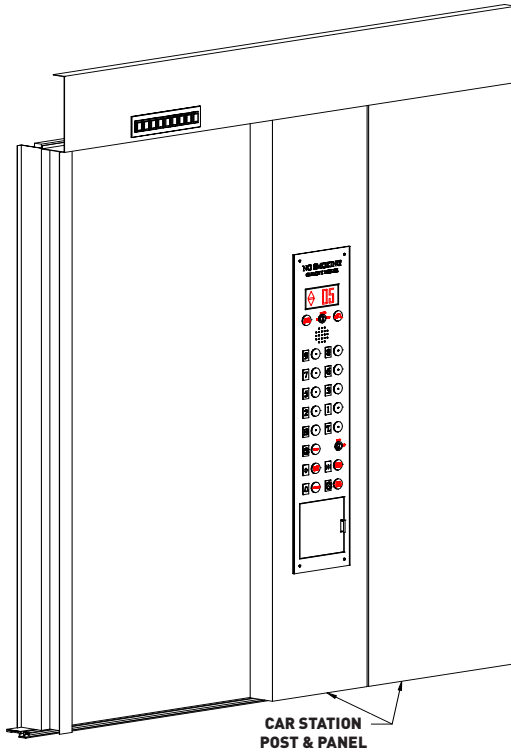

**CAR STATION POST  
& STATIONARY RETURN**

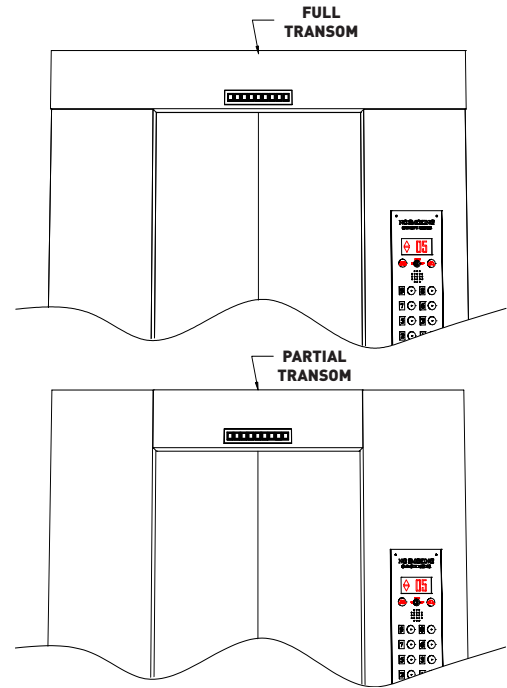

(Can be made removable for service type cars)

**FULL & PARTIAL  
TRANSOM**

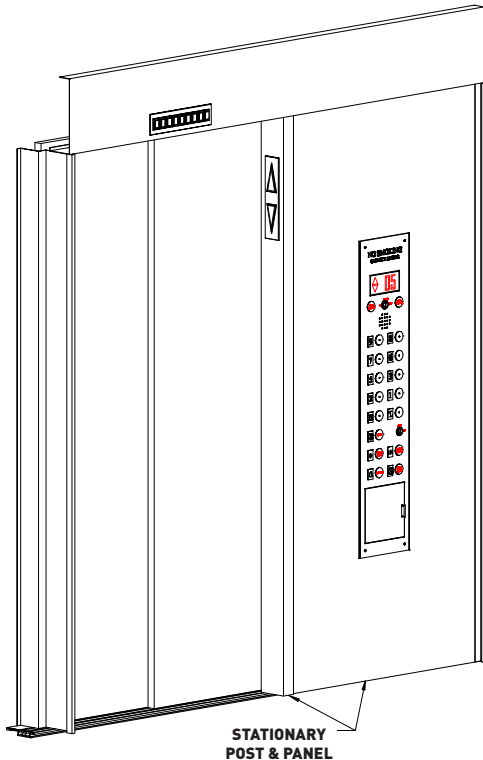

**STATIONARY POST  
& PANEL**

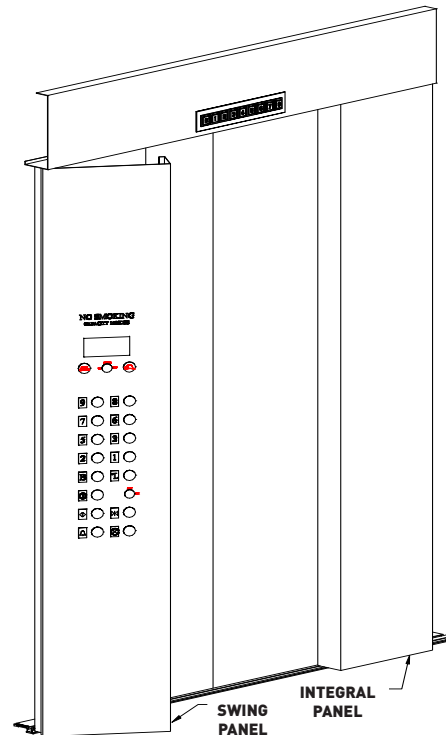

**INTEGRAL & SWING  
RETURN PANEL**

# WOODCORE AND STEEL SHELL CABS FOR ALL FIELD CONDITIONS

888-858-1558  
www.columbia-elevator.com  
info@columbia-elevator.com

## HANDRAILS

- SS #4 Round Tube, 1 1/2" or 2" diameter
- SS #4 Oval Tube, 2" x 1/2"
- SS #4 Flat Bar, 3" x 3/8"
- SS #4 Flat Bar, 4" x 1/4"
- SS #4 Flat Bar, 6" x 1/4"
- Bronze #4 Round Tube, 1 1/2" or 2" diameter
- Bronze #4 Flat Bar, 2" x 3/8"
- Provincial/Ornamental, Single or Multiple Rows, Single or Multiple Walls

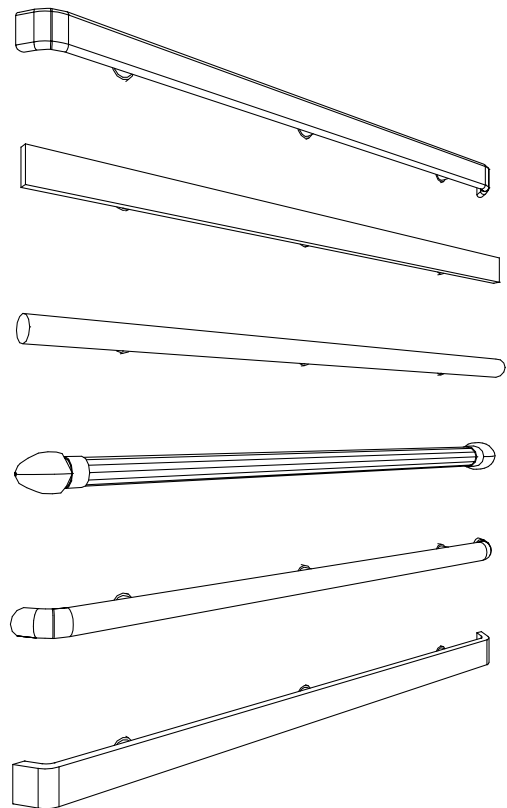

## WOOD CORE CABS

Provided with interlocking corner connectors for easy assembly

### Wainscot Finishes

- S/ST #4 Texture
- Aluminum Diamond Plate
- S/ST Diamond Plate
- Stone Finishes

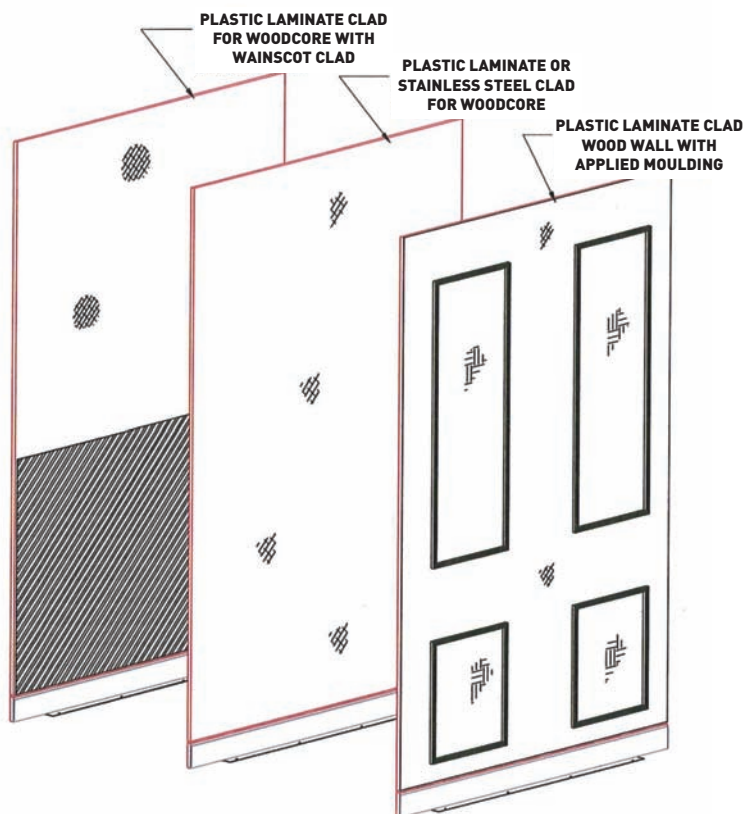

**WOOD WALL**

## HANDRAIL

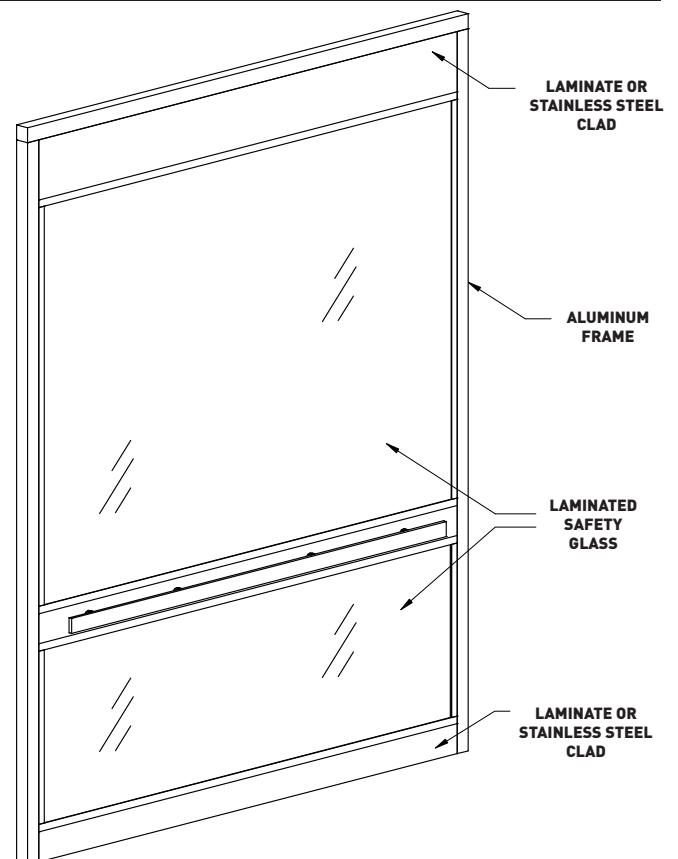

**GLASS WALL, ALUMINUM FRAME**

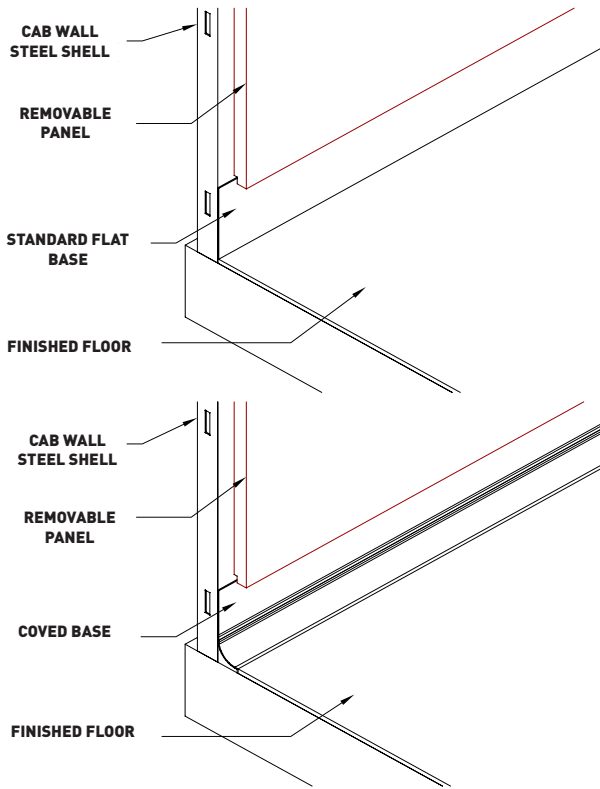

## STEEL SHELL CABS

Provided with Conventional Bolted Panel Construction

Or

Columbia's Patented Instafast™ Boltless Interlocking Joints

### Base Finishes

- Standard Baked Enamel Black
- Vinyl Coved
- Laminate
- S/ST #4
- S/ST #8
- Muntz/Bronze #4
- Muntz/Bronze #8

### Base Types

- Flat
- Coved

### Frieze Finishes

- S/ST #4
- S/ST #8
- Muntz/Bronze #4
- Muntz/Bronze #8

## STANDARD & COVED BASE

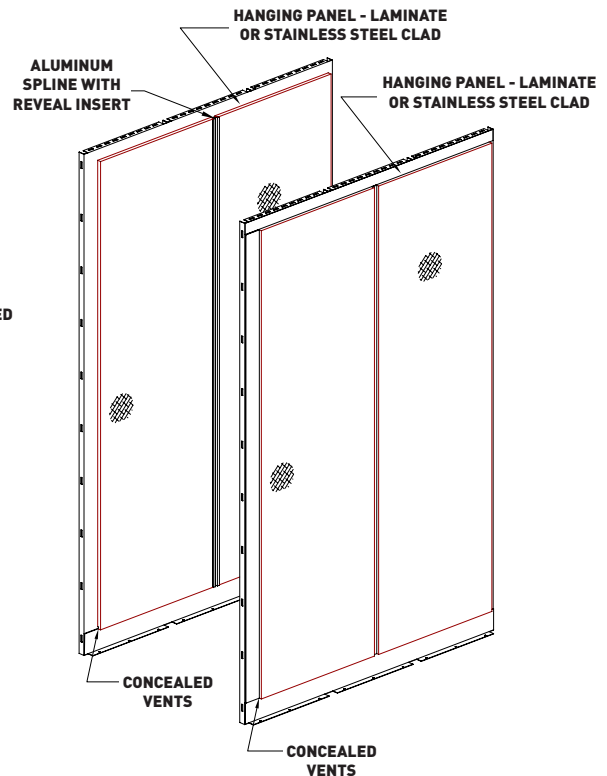
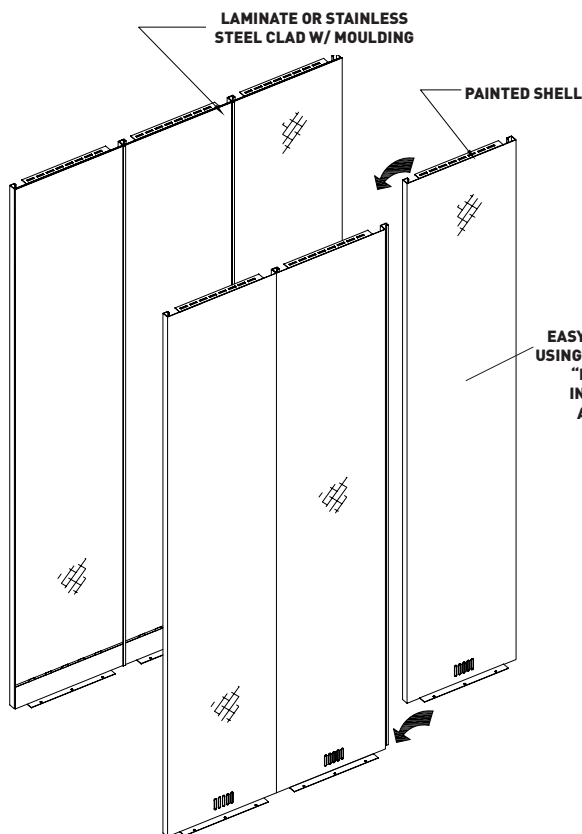

## STEEL SHELL

## REMOVABLE PANEL (STEEL SHELL)

## AESTHETICS AND SPECIAL APPLICATIONS

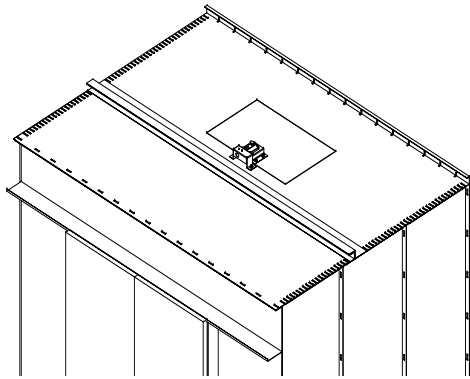

**FLAT CAR TOP**

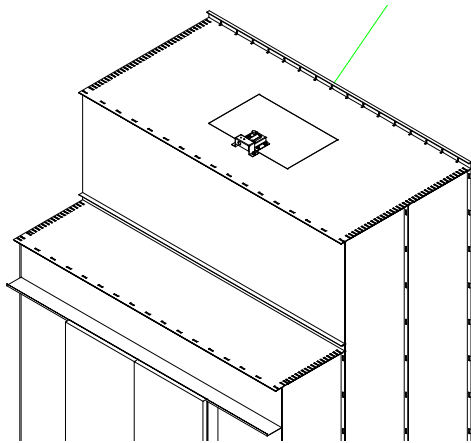

SHOWN AT REAR

**DOG HOUSE CAR TOP**

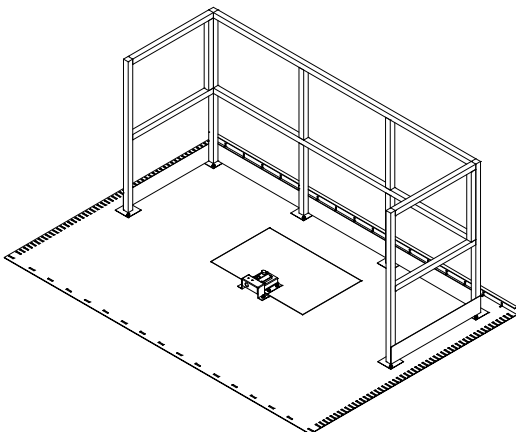

**CAR TOP RAILING**

### Downlight Options

- 50w Incandescent
- Halogen
- LED
- Twin Fluorescent, 9-13w

### Ceiling Finishes

- Baked Enamel
- Laminate
- S/ST #4
- S/ST #8
- Muntz/Bronze #4
- Muntz/Bronze #8

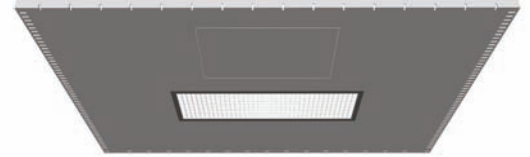

**CEILING WITH TAMPER PROOF, VANDAL RESISTANT LIGHTS**



**CEILING WITH DOWNLIGHTS**



17 WATT INCANDESCENT

**CEILING MINILIGHTS**



FIXED TO WALL OR FLOATING

**CANOPY LIGHT TROUGHS**

Available in baked enamel, stainless steel, or bronze

Option - stainless steel grille, lexan lamp guards



**SQUARE OR COVERED DOME  
CANOPY**

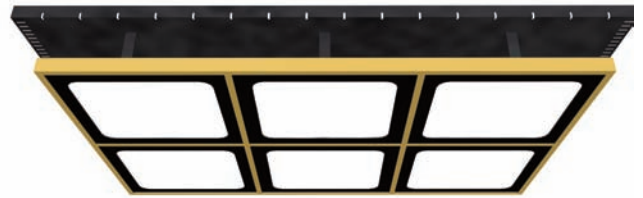

**SQUARE, ROUND OR  
PATTERNED LEXAN DISC  
DROP CEILING WITH FRAME**

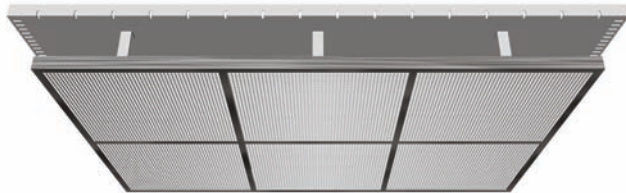

**ALUMIUM FRAME WITH LEXAN  
EGGCRATE DROP CEILING**

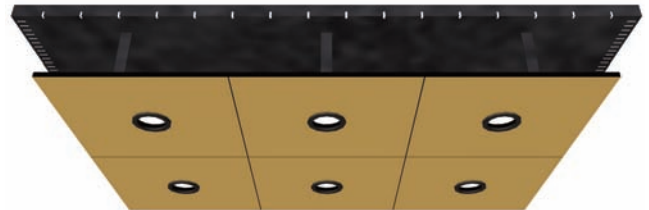

**STEEL OR WOODCORE PANEL  
DROP CEILING WITH  
DOWNLIGHTS**



**PATTERNED TRANSLUCENT  
LEXAN BACKED PANELS IN  
DROP CEILING WITH FRAME**



**STEEL OR WOODCORE PANEL  
DROP CEILING WITH  
MINI DOWNLIGHTS AND  
WOOD FRAME**

## CODE COMPLIANCE

Columbia leads the industry by prominently displaying an Underwriters Laboratories label on every product we make: cabs, doors, entrances and wireways. Columbia also offers the industry's only entrance assembly that is tested and certified by Warnock-Hersey Int. Inc. for compliance with NFPA 105 for smoke penetration (an industry exclusive).

In December, 1989, Columbia filed and tested a new classified elevator cab procedure in accordance with ASME/A17.1 section 204 (now section 2.14) -- the only UL-classified cab procedure in use. This Columbia exclusive ensures that UL is overseeing each phase of our cab construction, certifying that Columbia cabs are in full compliance with the fire resistivity, electrical shock and structural integrity requirements of the Elevator & Escalator Safety Code.

There is no other way to assure yourself, or inspecting authorities, that, once installed, your elevators cabs are actually built to Section 204 specifications (now section 2.14).



## SPECIALTY APPLICATIONS

In addition to commercial passenger cabs, Columbia offers an outstanding line of steel shell freight and Limited Use/Limited Application (LULA) cabs for commercial, institutional and residential installations.

### HOSPITAL SERVICE - FREIGHT

Columbia's freight cab line is tailor-made for the rugged/high impact environment of material or hospital patient handling. It features 14 gauge zinc coated wall and ceiling panels designed to accept enamel or clad finishes of various decorative and durable materials. Vertical wall and ceiling panels are designed for easy removal and replacement when damaged. Freight cabs are fabricated to the same strict UL manufacturing procedures followed in the construction of our passenger cabs.

### RESIDENTIAL - LULA

Columbia's LULA line was developed expressly to address today's post-ADA (Americans with Disabilities Act) environment: a product bridging the gap in applications where accessibility is an issue and code compliance conflicts with tight space requirements. These ADA-compliant cabs follow the same strict, in-plant UL inspected fabrication and labeling procedures as Columbia's commercial passenger and freight cabs, but have been designed with the additional considerations of the tight space/light weight criteria of the accessibility marketplace.



**COLUMBIA ELEVATOR PRODUCTS CO., INC.**

**THE LEADING EDGE IN CAB & DOOR SYSTEMS**

Phone: 888-858-1558

Fax: 866-865-7600

Website: [www.columbia-elevator.com](http://www.columbia-elevator.com)

E-Mail: [info@columbia-elevator.com](mailto:info@columbia-elevator.com)